



Dynamic DPH50M DPH50T DPH50SM

Geo Deep Drill S.r.L.
www.geodeepdrill.com info@geodeepdrill.it



packing list

- 10 rods ø28x1000 M18
- 2 recoverable tips
- 5 to lose tips
- 9 pipe coating

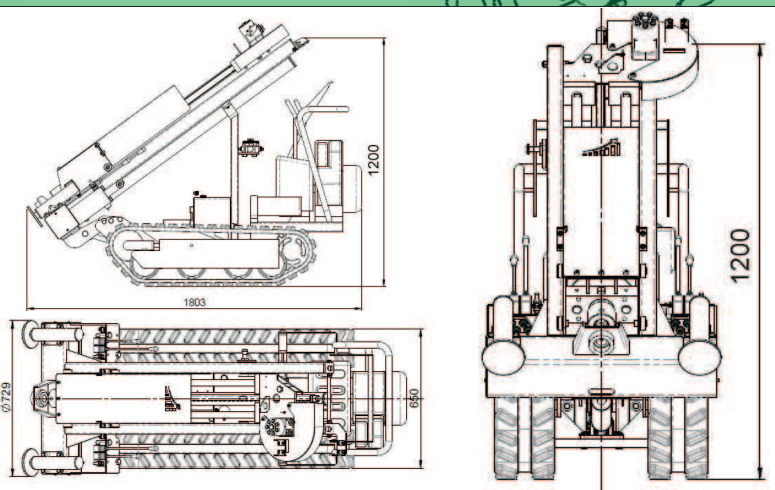

modello	DPH50M DPH50T DPH50SM
tipo	DINAMICO PESANTE CLASSIF. AGI - UNI
massa battente	50,0 kg - ø: 208 mm x H: 175 mm
altezza caduta	>50 cm (Evo. IV) 245 Joule
avanzamento	acquisizione ogni 10 / 20 cm
punta	ø 43,70 mm - angolo 90° - A 15,00 cm²
asta	acciaio 1000x22 mm M14 tacca 10,00 cm
rivestimento	42x1000 mm acciaio c40
frequenza colpi	10-60 colpi per minuto
stabilizzatori	a cilindro oleo. 15,00 cm
centralina	Briggs & Stratton 3,5 HP 3 lit/min 5litres
sottocarro	Khoeler 7 HP 8 lit/min 20lit. acc.elettrica
carburante	benzina serbatoio da 4,20L
olio idraulico	~7,00L OSO 40 (visc. 40° 41)
dimensioni	185x65x120cm colonna reclinata
peso	~500Kg su semovente base
parti rimovibili	3 (colonna, massa, serbatoio)
tipi di suolo	argilla, limo, sabbia fine
max profondità	>15m argilla, limo, sabbia
campionatore	fustella pvc ø 40x350mm 60x350mm
kit sondaggi	3 (coclea ø50x1000) + 3 (asta ø25x1000)
kit prova statica	non previsto



models	DPH50M DPH50T DPH50SM
kind	HEAVY DYNAMIC TEST AGI - UNI standards
hammer	50,0 kg - ø: 208 mm x H:175
height of fall	>50 cm 245 Joule
step	acquisition value every 10 / 20 cm
tip	ø 43,70 mm - angle 90° - area 15,00 cm²
rod	steel 1000x28 mm M18 mark 10,00 cm
coating	42x1000 mm steel c40
impact rate	10-60 strokes/minute
stabilizers	hydraulic cylinder 15,00 cm
power unit	Briggs & Stratton 3,5 HP 3 litres/min 5litres
carriage	Khoeler 7 HP 8 lit/min 20lit. electric ignition
fuel	gasoline tank 4,20L
hydraulic oil	7,00L OSO 40 (visc. 40° 41)
dimensions	185x65x120cm tilted mast
weight	~ 500kg on crawler
remov. parts	3 (mast, hammer, tank)
types of soil	clay, silt, fine sand
max depth	>15,00 m clay, silt, sand
sampler	pvc sampler ø 40x350mm 60x350mm
kit screw	3 (auger ø50x1000) + 3 (rod ø25x1000)
kit static (tip)	not available



modèle	DPH50M DPH50T DPH50SM
type	Dynamique Lourde CLASS. AGI - UNI
mouton	50,0 kg - ø: 208 mm x H: 175 mm
hauteur de chute	>50 cm (Evo. IV) 245 Joule
relevé de mesure	acquisition de données à 10 / 20 cm
pointe	ø 43,70 mm - angle 90° - A 15,00 cm²
tige	acier 1000x28 mm M18 marquage 10 cm
revêtement	42x1000 mm acier c40
vitesse de frappe	10-60 coups par minute
stabilisateurs	cylindre hydraulique 15,00cm
puissance mot.	Briggs & Stratton 3,5 HP 3 litres/min 5litres
chenillard	Khoeler 7 HP 8lit/min 20lit. allumage électrique
carburant	essence réservoir 4,20L
huile hydrau.	7,00L OSO 40 (visc. 40° 41)
dimensions	185x65x120 cm colonne inclinée
poids	~500 Kg on chenilles
pièces amovib.	3 (colonne, masse, réservoir)
types de sols	argile, silt, sable fin
profond. max.	>15m argile, silt, sable
echantillonneur	tube pvc ø 40x350mm 60/350mm
Kit sondage	3 tarières ø 50 x 1000 + 3 tiges ø 25
kit statique (tip)	pas disponible



modelo	DPH50M DPH50T DPH50SM
carateristica	Dinámico Pesado CLASS. AGI - UNI
peso de la maza	50,0 kg - ø: 208 mm x H: 175mm
altura de caída	>50 cm 245 Joule
penetración	adquisición 10 / 20 cm
punta	ø 43,70 mm - esquina 60° - A 15,00 cm²
verilla	acero 1000x28 mm M18 mark 10,00 cm
revestimiento	42x1000 mm acero c40
frecuencia	10-60 golpes por minuto
estabilizadores	cilindro hidráulico 15,00 cm
central oleo.	Briggs & Stratton 3,5 HP 3 litres/min 5litres
carro	Khoeler 7 HP 8lit/min 20lit. arranque eléctrico
carburante	depósito de gasolina da 4,20L
aceite hidráulico	7,00L OSO 40 (visc. 40° 41)
dimensiones	185x65x120 columna inclinada
peso	~ 500kg on orugas
piezas removib.	3 (columna, martillo, caja)
tipo suelo	arcilla, limo, arena fina
máxima profund.	>15m arcilla, limo, arena
sampler	punzón hueco pvc ø 40x350mm 60x350mm
kit sondeos	3 (cóclea ø50x1000) + 3 (barra ø25x1000)
kit estático (tip)	no disponible