



Static SP50M SP50T SP50SM

Geo Deep Drill S.r.L.
www.geodeepdrill.com info@geodeepdrill.it



packing list

- 8 rods ø36x1000
- 1 Begemann tip
- 2 auger ø100x700 Mtip
- 2 auger ø100x700 MF
- 2 rods ø32x700 MF

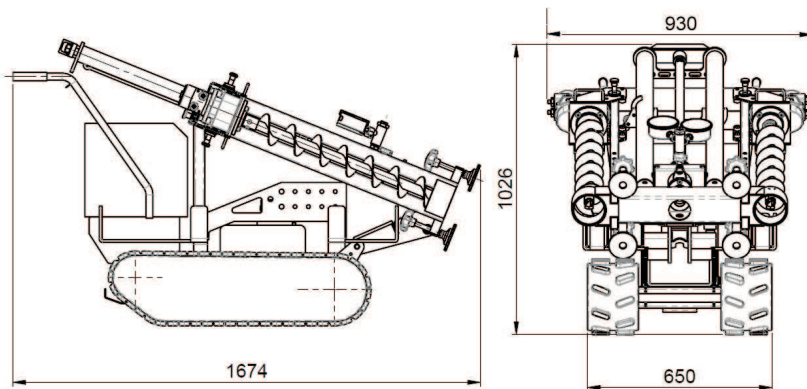

modello	SP50M SP50T SP50SM
tipo	STATICO 5t AGI - UNI
spinta	spinta in infissione: 50 kN (5t)
trazione	trazione in estrazione: 67 kN
avanzamento	acquisizione da 1 a 20 cm
punta	Begemann CPT / CPTU SCPT CPTE
asta	aste da 1000x36 mm + 1000x15 mm C38
velocità	1,00 m for 50" 1,00 m for 20"
ancoraggio	coclee ø 10x70 cm ø 10x50 cm
lettura dati	2 manometri ø100mm (0-40) (0-250)bar
centralina	7 HP accensione elettrica 4 lit/min oil
sottocarro	Khoeler / Lombardini
carburante	benzina serbatoio da 4,20L
olio idraulico	~9,00L OSO 40 (visc. 40° 41)
dimensioni	170x93x103cm colonna reclinata
peso	~400Kg su semovente base
parti rimovibili	3 (colonna, massa, serbatoio)
tipi di suolo	argilla, limo, sabbia fine
max profondità	<15m argilla - limo , sabbia
campionatore	fustella pvc ø 40-60-80x350mm
kit sondaggi	3 (coclea ø38x800) + 3 (asta ø25x800)
kit dinamico	DM30 (30kg x 20cm)



models	SP50M SP50T SP50SM
kind	STATIC 5t TEST PENETROMETER
push down force	50 kN (5t)
extraction	traction in extraction: 67 kN (7t)
step	acquisition value every 1 / 20 cm
tip	Begemann CPT / CPTU SCPT CPTE
rod	1000x36 mm +1000x15 mm (C38 steel)
acquisition	1,00 m for 50" 1,00 m for 20"
anchorage	auger ø 10x70 cm ø 10x50 cm
reading data	2 gouges ø100mm (0-40) (0-250)bar
power unit	7 HP electric ignition 4 lit/min oil
carriage	Khoeler / Lombardini
fuel	gasoline tank 4,20L
hydraulic oil	9,00L OSO 40 (visc. 40° 41)
dimensions	170x93x103cm tilted mast
weight	~ 400kg on crawler
remov. parts	3 (mast, hammer , tank)
types of soil	clay , silt , fine sand
max depth	<15,00 m clay, silt , sand
sampler	pvc sampler ø 40-60-80x350mm
kit screw	3 (auger ø38x800) + 3 (rod ø25x800)
dynamic test kit	DM30 (30kg x 20cm)



modèle	SP50M SP50C SP50SM
type	STATIQUE AGI - UNI
poussée	poussée: 53 kN (5.3t)
traction	arrachement 70kN (7.0t)
relevé de mesure	acquisition de données à 1 / 20 cm
pointe	Begemann CPT / CPTU SCPT CPTE
tige	1000x36 mm / 1000x15 mm C38
vitesse colonne	1,00 m for 50" 1,00 m for 20"
ancrage	tarière ø 10x70 cm ø 10x50 cm
lecture données	2 manomètres ø100mm (0-40) (0-250)bar
puissance mot.	7 HP allumage électrique 4 lit/min oil
chenillard	Khoeler / Lombardini
carburant	essence réservoir 4,20L
huile hydrau.	9,00L OSO 40 (visc. 40° 41)
dimensions	170x93x103cm colonne inclinée
poids	~400 Kg on chenilles
pièces amovib.	3 (colonne, masse, réservoir)
types de sols	argile, silt, sable
profond. max.	<15m argile, silt ,sable
echantillonneur	tube pvc ø 40-60-80/350mm
kit d'échantillon.	3 (tarière ø38x800) + 3 (tige ø25x800)
kit dynamique	DM30 (30kg x 20cm)



modelo	SP50M SP50C SP50SM
carateristica	STATIC AGI - UNI
empuje	empuje: 53 kN (5.3t)
tracción	70kN (7.0t)
penetración	adquisición 10/20 cm
punta	Begemann CPT / CPTU SCPT CPTE
verilla	1000x36 mm / 1000x15 mm C38
velocidad colum.	1,00 m for 50" 1,00 m for 20"
anclase	cóclea ø 10x70 cm ø 10x50 cm
lectura de datos	2 manómetros ø100mm (0-40) (0-250)bar
central oleo.	7HP arranque eléctrico 4 lit/min oil
carro	Khoeler / Lombardini
carburante	depósito de gasolina da 4,20L
aceite hidráulico	9.00L OSO 40 (visc. 40° 41)
dimensiones	170x93x103cm columna inclinada
peso	~400kg on orugas
piezas removib.	3 (columna, peso, tanque)
tipo suelo	arcilla, limo, arena
máxima profund.	<15m arcilla, limo , arena
probador	punzón hueco pvc ø 40-60-80x350mm
kit sondeos	3 (ø38x800 tornillo) + 3 (ø25x800 extensión)
kit dinámico	DM30 (30kg x 20cm)